

WIRE BASKET SOLUTIONS



DELIVERING INNOVATION
www.marshall-tufflex.com

UK OWNED
UK MANUFACTURER



3E Basor
CABLE TRAY SPECIALIST



WIRE BASKET SYSTEMS

A range of Fast Coupling Wire Basket for the simple routing of power and data cables. Strong and simple to install, Basor Wire Basket offers maximum cable ventilation and a high level of resistance to cable movement.

Connection between sections of wire basket is quick and easy thanks to the integral couplers which results in reduced installation times and labour savings.

A unique rippled wire design enhances the product strength and resists flexing.



Fast-Coupling

Fast-Coupling Wire Basket is quick and simple to install:

- Two step mounting: fitting and pressure.
- The couplers at the end of the tray are used as guides in the assembly process.
- Once the couplers are connected the system offers excellent earth continuity across the joints.

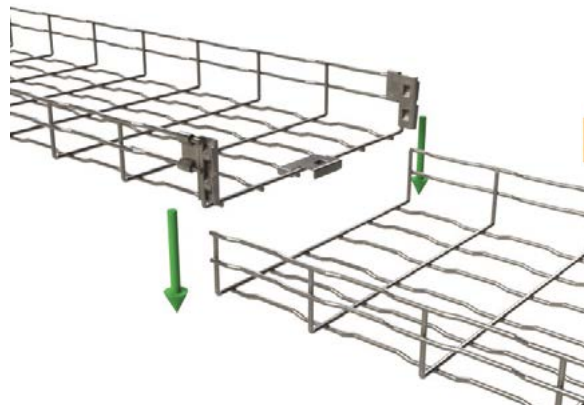

Materials and suitable applications

Our standard wire basket is electro-zinc coated and is recommended for interior installations.

We can provide a quotation for hot dip galvanised or stainless steel finishes to suit exterior installations but these are subject to longer lead times. The below table identifies the finish suitable for the environment.

		EZ Electro-Zinc	HDG Hot-Dip Galvanised Steel	SST Stainless-Steel (316 grade)
Interior	Dry	Recommended	Overspecified	Overspecified
	Humid	Limited Resistance	Recommended	Overspecified
	Chemical industry	Not recommended	Limited Resistance	Overspecified
	Food industry	Not recommended	Not recommended	Overspecified
Exterior	Urban	Limited Resistance	Recommended	Overspecified
	Chemical industry	Not recommended	Limited Resistance	Overspecified
	Food industry	Not recommended	Limited Resistance	Recommended

Approvals



- UL Certification E358301 EN61537 – Cable Management
- IEC 61537:2006 Cable management – Cable tray systems and cable ladder systems.



Rippled design

The unique rippled design of the base of the basket allows for the easy threading of cable ties and increased load capacity with greater resistance to flexing.

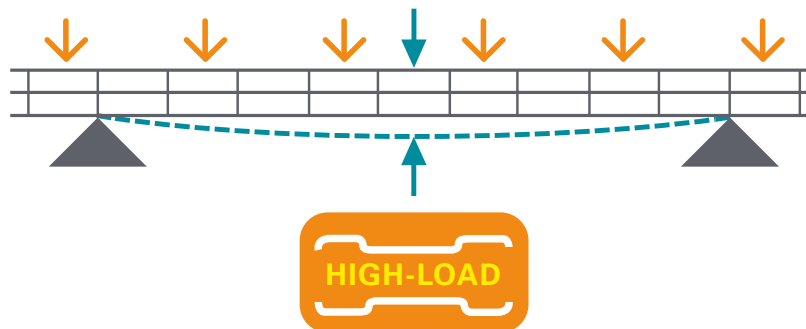

Innovative patented design which offers:

- Greater resistance to flexing
- Greater safe working load
- Excellent aesthetic finish



Useful area

Base Width	Standard Basket 35mm Height*		Fast Coupling 65mm Height		Fast Coupling 105mm Height	
	in ²	cm ²	in ²	cm ²	in ²	cm ²
60	–	–	3.57	23	–	–
100	4.18	27	7.29	47	–	–
150	6.51	42	11.63	75	–	–
200	8.99	58	15.81	102	28.83	186
300	13.80	89	24.34	157	45.11	291
400	–	–	32.86	212	61.38	396
500	–	–	41.39	267	77.66	501
600	–	–	49.91	322	93.93	606

*Please note our 35mm wire basket does not have integral couplers

FAST-COUPLING WIRE BASKET

A fast-coupling system allowing sections of wire basket to be simply joined together for super-fast installation using the integral couplers.

- Two heights available; 65mm and 105mm
- Integral couplers for quick and easy connection in just two steps and only 4 seconds!
- The position of the couplers create a guide making a fast and easy assembly process
- No tools required
- Reduced installation time, saving labour costs
- Strong and lightweight
- Unique rippled wire design to enhance product strength and resist flexing
- Maximum cable ventilation and a high level of resistance to cable movement
- Safety edges to prevent cable damage and personal injury
- Optimal solution for installations that do not require big loads
- Simple manipulations to the wire basket can overcome complicated changes in direction
- Electro-Zinc finish
- Corrosion resistance, can be used in harsh environments
- Fire resistant to E90 DIN 4101 section 12



Standard finish

EZ

EZ: Electro-Zinc

Wire Basket is available in Electro-Zinc as standard.

Finish options: HDG (hot-dip galvanised steel) and SST (stainless steel) are available but these are subject to minimum quantity orders and longer lead times.

65mm Height



Fast-Coupling Wire Basket 65mm Height

code	description	dimensions (mm)			pack
		width	height	length	
MT2/7389	60 x 65mm	60	65	3000	2 x 3m
MT2/7248	100 x 65mm	100	65	3000	2 x 3m
MT2/7249	150 x 65mm	150	65	3000	2 x 3m
MT2/7250	200 x 65mm	200	65	3000	2 x 3m
MT2/7251	300 x 65mm	300	65	3000	2 x 3m
MT2/7394	400 x 65mm	400	65	3000	2 x 3m
MT2/7395	500 x 65mm	500	65	3000	2 x 3m
MT2/7396	600 x 65mm	600	65	3000	2 x 3m

105mm Height



Fast-Coupling Wire Basket 105mm Height

code	description	dimensions (mm)			pack
		width	height	length	
MT2/7397	200 x 105mm	200	105	3000	2 x 3m
MT2/7398	300 x 105mm	300	105	3000	2 x 3m
MT2/7399	400 x 105mm	400	105	3000	2 x 3m

Covers

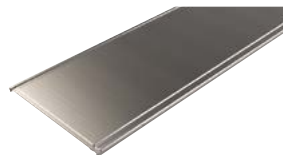

- Cover eliminates dirt and dust build-up on cable
- Provides physical protection for cables
- Galvanised steel finish
- To mount the cover no accessories are needed – fixed by pressure

Please note: This cover is for 35mm & 65mm basket only. For 105mm version please contact our Technical Team on +44 (0)1424 856688.

Wire Basket Cover

code	description	dimensions (mm)		weight (kg) per metre	pack
		width	length		
MT2/1312	Cover 100mm	102	3000	0.55	2 x 3m
MT2/1313	Cover 150mm	152	3000	0.76	2 x 3m
MT2/1314	Cover 200mm	202	3000	0.98	2 x 3m
MT2/1316	Cover 300mm	302	3000	1.55	2 x 3m
MT2/1317	Cover 400mm	402	2000	2.19	2 x 2m
MT2/1318	Cover 500mm	502	2000	3.11	2 x 2m
MT2/1319	Cover 600mm	602	2000	3.95	2 x 2m

STANDARD WIRE BASKET

An innovative wire basket solution to accommodate high cable loads.

- High cable capacity
- Maximum cable ventilation and a high level of resistance to cable movement
- Ripple design offers greater resistance to flexing
- Greater safe working load
- Excellent aesthetic finish
- Assemble using our range of Fast Fix Clip on couplers – no bolts required
- 35mm height



Standard finish
EZ
EZ: Electro-Zinc





Wire Basket is available in Electro-Zinc as standard.

Finish options: HDG (hot-dip galvanised steel) and SST (stainless steel) are available but these are subject to minimum quantity orders and longer lead times.

35mm Height



Standard Wire Basket 35mm Height

code	description	dimensions (mm)			pack	
		width	height	length		
MT2/3616	100 x 35mm	100	35	3000	2 x 3m	
MT2/3617	150 x 35mm	150	35	3000	2 x 3m	
MT2/3618	200 x 35mm	200	35	3000	2 x 3m	
MT2/3619	300 x 35mm	300	35	3000	2 x 3m	



Fast fix clip on coupler - 35mm

code	pack
MT2/7271	10



Fast fix clip on coupler - 65mm and 105mm

code	pack
MT2/6217	10

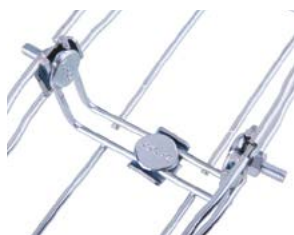

Basket connector bolt

code	pack
MT2/4364	10



Basket connector bracket

code	pack
MT2/4919	10



Nut and bolt

code	pack
MT2/4362	10



Ceiling support plate

code	pack
MT2/2064	10

Please note: these are sold in singles; two are needed for fittings as per the image. Nut and bolt are not supplied.



Wall bracket support plate

code	pack
MT2/0355	10



Conduit feed plate

code	pack
MT2/18798	20

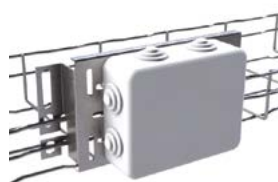

Universal box plate

code	description	pack
MT2/0358	Large universal box plate	4
MT2/0359	Small universal box plate	8



Side support clip 65mm and 105mm

code	pack
MT2/0360	10



Cable drop out plate

code	pack
MT2/6451	1



Bend connector bolt

code	pack
MT2/5059	1



Side support clip

code	pack
MT2/5724	1

Accepts 10mm mounting stud



Floor bracket

code	pack
MT2/5590	1



Lighting attachment plate

code	pack
MT2/5906	1

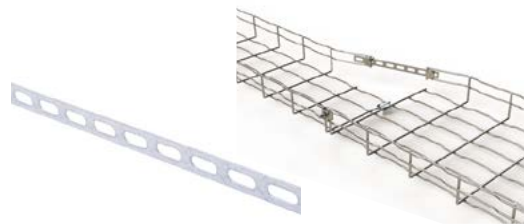

Multi-union joint

code	pack
MT2/0357	1



Cutting tool

code	pack
MT2/5066	1



Spray paint 98% zinc

code	pack
MT2/7224	1



Clip to secure basket to strut

code	pack
MT2/10284	10



Variable support bracket

code	pack
MT2/6477	10



M8 threaded rod

code	pack
MT2/3397	10 x 1m



M8 nut

code	pack
MT2/0338	10



Earth bonding connector

code	pack
MT2/6797	10



Self fixing dividing fillet

code	description	pack
MT2/3476	35mm	10 x 3m
MT2/2066	60mm	10 x 3m
MT2/3478	100mm	10 x 3m

Attaches to wire basket using self fixing clip



Bracket for 60x65 wire basket

code	pack
MT2/7304	1



Fast fix wall bracket

code	description	pack
MT2/7230	100mm	1
MT2/7231	150mm	1
MT2/7232	200mm	1
MT2/7233	300mm	1
MT2/7234	400mm	1



Wall bracket supporting piece

code	pack
MT2/6240	1

Ceiling brackets



Fast fix ceiling bracket

code	description	height	pack
MT2/7235	100mm	175mm	1
MT2/7236	150mm	175mm	1
MT2/7237	200mm	175mm	1
MT2/7238	300mm	175mm	1

Suspension frames



Fast fix suspension frame base (rods sold separately)

code	description	pack
MT2/3630	100mm	1
MT2/1073	150mm	1
MT2/1074	200mm	1
MT2/1076	300mm	1
MT2/3629	400mm	1
MT2/1077	500mm	1
MT2/5941	600mm	1



Support strut leg

code	leg height	pack
MT2/5602	142mm	1



Stand off bracket

code	description	pack
MT2/1046	100mm	1
MT2/1047	150mm	1
MT2/1048	200mm	1
MT2/1049	300mm	1
MT2/3413	400mm	1
MT2/3414	500mm	1
MT2/3415	600mm	1

CABLELAY MATTING FOR WIRE BASKET AND TRAY SYSTEMS

Cablelay is laid within lengths of wire basket or tray to protect cables from protrusions, sharp edges, rough surfaces and kinking ridges thus maintaining the integrity of the data cables which lay on top.

Damaged cabling considerably slows down system performance, causes loss of data and costs hours of additional work time. Our Cablelay products are designed to minimise the risk of damage often caused during installation and protects the cabling for the lifetime of the system.

- A lightweight and flexible 6mm thick mat supplied on rolls for quick and easy installation.
- Class 0 fire standard to meet Building Regulations for England and Wales
- Rolls are joined using Cablelay tape which maintains the Fire Standard and prevents joint movement
- Reduces moisture getting absorbed into the cables and impacting on data cable performance

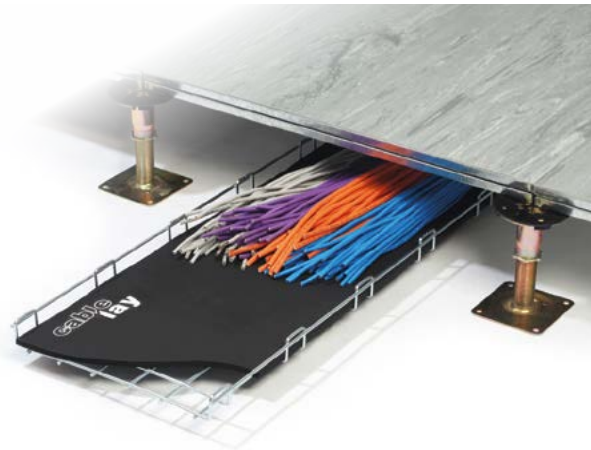

Cablelay Matting Meets Building Regulations

Quality assurance and health and safety issues are becoming increasingly more important, Class 0 Cablelay has an excellent fire safety performance complying with Building Regulations by passing both BS476 parts 6 and 7 for fire propagation and surface spread of flames.

Cablelay Matting



Cablelay Matting Class 0

code	width	pack
WBM0660	60mm	1 x 30m
WBM06100	100mm	1 x 30m
WBM06150	150mm	1 x 30m
WBM06200	200mm	1 x 30m
WBM06300	300mm	1 x 30m
WBM06400	400mm	1 x 30m
WBM06500	500mm	1 x 30m
WBM06600	600mm	1 x 30m

Accessories



Cablelay Tape

code	description	pack
WBMLT	LSOH	1 x 15m roll

Material

Electrogalvanised (ELECTROZINC/EZ)

A steel base coated with a zinc layer by electrolysis, by means of submerging the lengths in a bath composed of a zinc solution, in accordance with BS EN ISO 2081. Depending on the type of zinc layer, it shall have a different degree of protection on the steel, avoiding corrosion and enhancing the visual appearance of the length. This treatment is carried out once the length has been formed. The IEC 61537 Standard classifies the degree of resistance to corrosion of the system's components depending on the steel's electrolytic covering, belonging to Class 1 those with a minimum thickness of 5µm and to Class 2 those of 12µm. Marshall-Tufflex uses Class 2 as its standard material in order to guarantee the quality of its products against corrosion. This treatment is used in dry environments free of pollutants.

Hot Dip Galvanised Steel (HDG) Non-standard material

Laminated or rust removed galvanised after forming steel according to BS EN ISO 1461 Standard. The steel's protection is covered by a zinc coating which varies depending on the steel's thickness, offering a uniform covering. The zinc coating's thickness depends on the thickness of the base material. The IEC 61537 Standard classifies the resistance against corrosion of these galvanised steels as Class 5 for the covering of 45µm, Class 6 for 55µm, Class 7 for 70µm and Class 8 for 85µm. Hot dip galvanised steel is used in humid environments, granting a high protection during adverse atmospheric situations, light chemical situations, light marine situations and urban situations.

Stainless Steel AISI 316 (I316) Non-standard material

Denominated 14401 according to the numerical classification established by the BS EN 10088 Standard. Steel's protection happens due to the great affinity which metals such as chromium have with oxygen, which gives place to the creation of a protective chromium oxide layer which avoids the corrosion of iron. Type I316 stainless steels are similar to type 1304, but they contain a 2.5% of molybdenum which confers it a greater resistance to localised corrosion. It is ideal for use in very corrosive environments, even at high temperatures. Under special conditions, and always under order, there is the possibility of conducting a passivation process. Passivation is a treatment which enhances stainless steel's protection against corrosion by means of forming a relatively inert film on the surface of a material which protects it against the action of external agents. The passivation

film or layer does not allow these agents to interact, reducing or stopping the chemical reaction from happening.

IEC 61537 Standard classifies this steel's resistance to corrosion as Class 9B without the passivation treatment and as Class 9D with the passivation treatment.

Stainless Steel AISI 316L, denominated 14401 according to the numerical classification established by the BS EN 10088 Standard has the same characteristics regarding corrosion as steel AISI 316, but offers a higher degree of welding and easier forming of the lengths with a thickness of more than 6mm.

Dimensions

Height 35mm

Standard Wire Basket

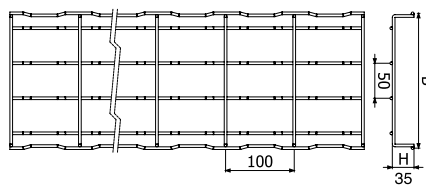

Please note:
B is equal to listed width of basket.

Height 65mm

Fast-Coupling Wire Basket

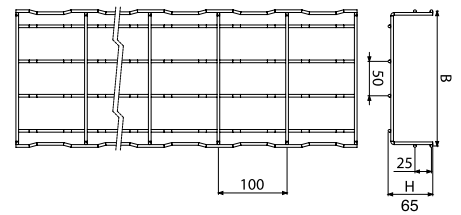

Height 105mm

Fast-Coupling Wire Basket

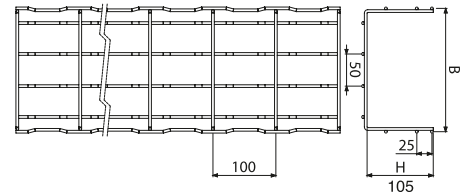

Cover

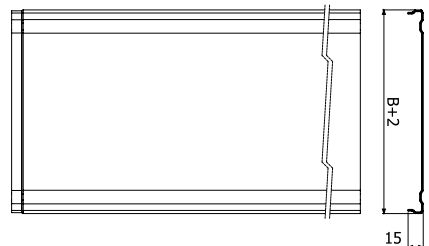

Working temperature

	Minimum working temperature	Maximum working temperature	According to Standard
Standard Wire Basket 35mm	-50°C	+150°C	IEC 61537
Fast-Coupling Wire Basket 65mm	-50°C	+150°C	IEC 61537
Fast-Coupling Wire Basket 105mm	-50°C	+150°C	IEC 61537

Resistance to corrosion

Atmospheric corrosion

Atmospheric corrosion happens when metal is exposed to liquids, solids or gases. Humidity, salt corrosive gases and dirt are its main factors. Atmospheric corrosion takes place in open air conditions, areas with poor ventilation and marine environments.

Saline corrosion happens when a metallic surface is exposed to different saline concentration levels forming a galvanic pile. At times where the surface is exposed to the lowest degree of saline concentration this will then behave as an anode for the corrosion to take place.

Chemical corrosion

Chemical corrosion happens when metal is directly exposed to chemical solutions. Depending on the concentration of the solution, contact time, cleaning frequency and ambient temperature the level of corrosion will be higher or lower.

Galvanic corrosion

Galvanic corrosion is the most common type of corrosion, and happens when two different metals are in contact with one another. When two different metals come into contact a small galvanic particle is created, as one metal acts as an anode the other acts as a cathode. The metal with the most negative reduction potential shall oxidise whilst the metal with the most positive charge shall have less corrosion.

Storage conditions

The product must be stored in a dry and well ventilated area. The product must not be stored outside even in low humidity conditions.

Free base area

Base size	Classification	Free base area
60	Y	Over 80% and up to 90%
100	Y	Over 80% and up to 90%
150	Y	Over 80% and up to 90%
200	Y	Over 80% and up to 90%
300	Y	Over 80% and up to 90%
400	Y	Over 80% and up to 90%

To show the installation designer the level of ventilation allowed for the cable tray, the IEC 61537 standard established that the manufacturer has to inform of the percentage of the base 'free' (without material, in solid cable trays this means the "degree of perforation").

Safe working load (SWL)

The safe working load (SWL) is the maximum load which can be applied during normal use, without danger. Therefore, the workload shall always be less than the SWL.

The SWL of our products are calculated in accordance with IEC 61537. For any further information contact our Technical Team in +44 (0)1424 856688.

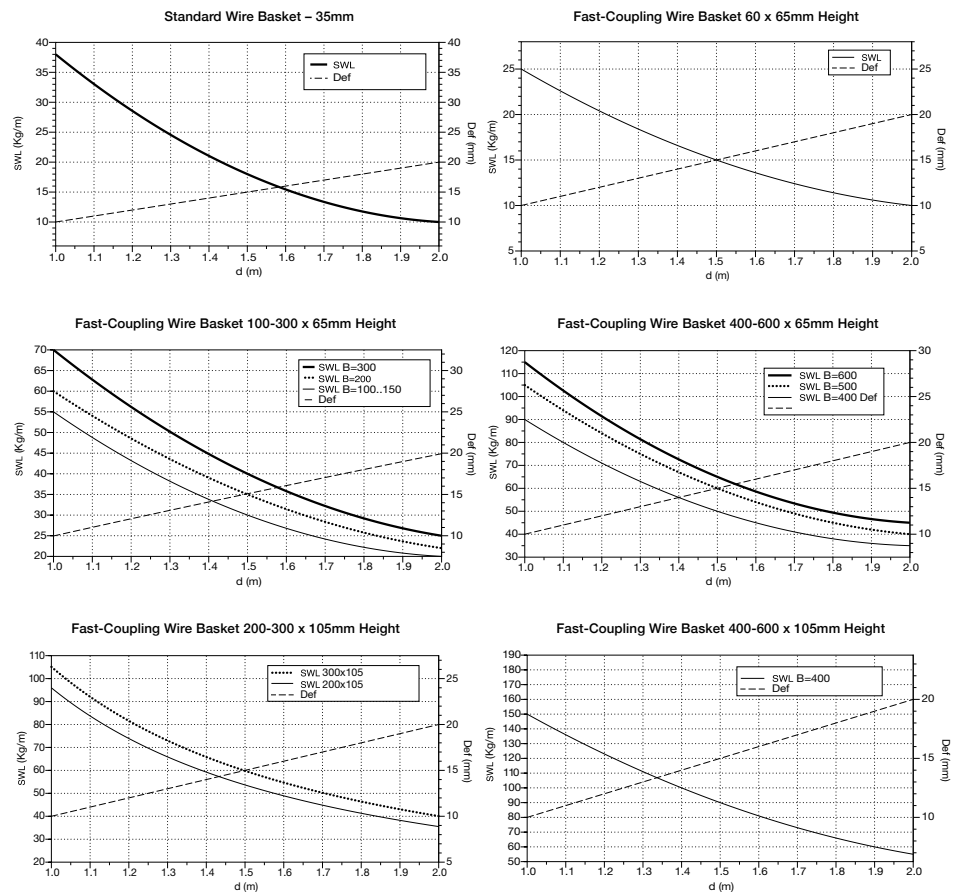

Please note:

d is equal to distance between supports

Def = deflection

Cable capacities

- All calculations allow for a 45% space factor.

As there can be differences between data cable sizes, Marshall-Tufflex recommend that cable dimensions are confirmed with the manufacturing company.

Basket Width (mm)	35mm Standard Basket			65mm Fast-coupling Wire Basket			105mm Fast-coupling Wire Basket		
	Without Matting	Flexible Matting	Rigid Matting	No Cablelay	With Cablelay Matting	With Cablelay Rigid	No Cablelay	With Cablelay Matting	With Cablelay Rigid
Data Cable: Ø5.5mm									
60	-	-	-	43	39	41	-	-	-
100	51	42	46	89	80	84	-	-	-
150	79	65	72	142	127	134	-	-	-
200	109	89	99	193	173	183	365	345	355
300	168	137	152	297	266	281	562	531	546
400	-	-	-	401	358	380	759	716	738
500	-	-	-	505	451	478	-	-	-
600	-	-	-	609	544	577	-	-	-
Data Cable: Ø6mm									
60	-	-	-	36	33	34	-	-	-
100	42	35	39	74	67	71	-	-	-
150	66	54	60	119	107	113	-	-	-
200	92	75	83	162	145	153	307	290	298
300	141	115	128	249	223	236	472	446	459
400	-	-	-	337	301	319	638	602	620
500	-	-	-	424	379	402	-	-	-
600	-	-	-	512	457	485	-	-	-
Data Cable: Ø6.5mm									
60	-	-	-	31	28	29	-	-	-
100	36	30	33	63	57	60	-	-	-
150	56	46	51	101	91	96	-	-	-
200	78	64	71	138	124	131	261	247	254
300	120	98	109	212	190	201	402	380	391
400	-	-	-	287	256	272	543	513	528
500	-	-	-	362	323	342	-	-	-
600	-	-	-	436	389	413	-	-	-
Data Cable: Ø7mm									
60	-	-	-	26	24	25	-	-	-
100	31	26	28	54	49	52	-	-	-
150	49	40	44	87	78	83	-	-	-
200	67	55	61	119	106	113	225	213	219
300	104	84	94	183	164	173	347	327	337
400	-	-	-	247	221	234	468	442	455
500	-	-	-	312	278	295	-	-	-
600	-	-	-	376	336	356	-	-	-
Data Cable: Ø8.4mm									
60	-	-	-	18	16	17	-	-	-
100	21	18	20	38	34	36	-	-	-
150	34	28	31	60	54	57	-	-	-
200	47	38	42	82	74	78	156	148	152
300	72	58	65	127	114	120	241	227	234
400	-	-	-	172	153	163	325	307	316
500	-	-	-	216	193	205	-	-	-
600	-	-	-	261	233	247	-	-	-

Load table

Find out the load capacity of all our wire baskets. We recommend that you plan for extra space in cable pathways during the initial installation to allow capacity for future cable additions.

For spacing factors please refer to the current version of the BS 7671 Wiring Regulations.

MT Code	Description	Weight kg/m
MT2/3616	Standard 100x35mm	0.55
MT2/3617	Standard 150x35mm	0.69
MT2/3618	Standard 200x35mm	0.83
MT2/3619	Standard 300x35mm	1.18
MT2/7389	Fast coupling 60x65mm	0.54
MT2/7248	Fast coupling 100x65mm	0.79
MT2/7249	Fast coupling 150x65mm	0.84
MT2/7250	Fast coupling 200x65mm	1.09
MT2/7251	Fast coupling 300x65mm	1.60
MT2/7394	Fast coupling 400x65mm	1.94
MT2/7395	Fast coupling 500x65mm	2.72
MT2/7396	Fast coupling 600x65mm	3.13
MT2/7397	Fast coupling 200x105mm	1.59
MT2/7398	Fast coupling 300x105mm	1.93
MT2/7399	Fast coupling 400x105mm	2.71

EMC and data

It is recommended to separate power and data circuits by a minimum of 20cm. (EN 50174-2)

Where power and data circuits must cross, this must be done at 90 degrees.

Wire Basket systems without electrical continuity do not protect against electromagnetic fields. Make sure electrical continuity is preserved by using the appropriate earth bonding accessories.

Electrical continuity

Our Fast-Coupling Wire Basket conforms to IEC 61537. The wire mesh basket has an impedance lower than:

50mΩ across the joint

5mΩ per metre in a straight section

Fire resistance

Marshall-Tufflex and Basor Electric certifies that the wire basket installed with the below mentioned characteristics complies with Class E90 of function maintenances, in accordance with Standard DIN 4102, Section 12.

This system incorporates Standard Wire Basket with a height of 65mm.

This system uses Fast Fix Wall Bracket supports fixed to the wall and reinforced on the ceiling using the Variable Support Bracket, M8 Threaded Rod and M8 Nut on one side, as per the below image.

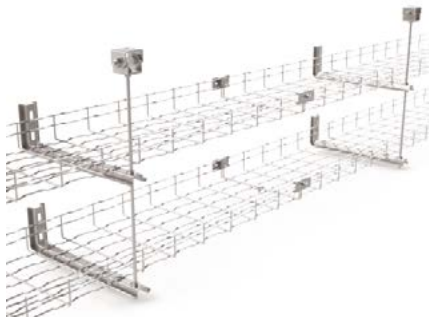

The distance between supports is of 1.2m and the maximum load is of 10kg/m. The system may have one or two levels.

Earth bonding

For earth bonding requirements please refer to the current version of the BS 7671 Wiring Regulations.

Installation

The following drawings show in red the sections that should be removed to make the associated join or bend.

Horizontal bend from two straight sections

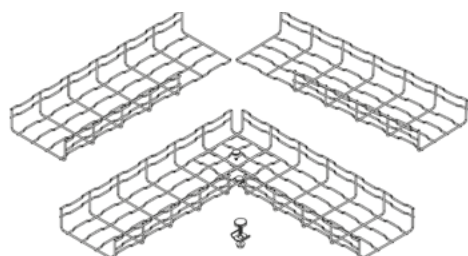

Cutting

Always use asymmetrical cut wire cutters. Cut as close as you can to where horizontal and vertical rods cross each other, as shown.

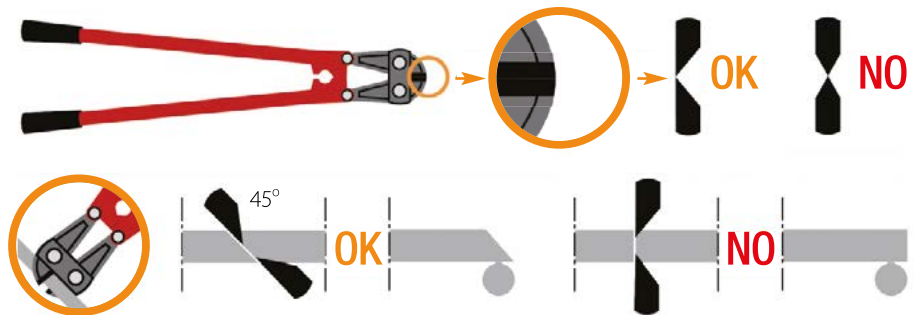

We recommend always placing the basket on a flat surface to make the cuts.

Wire gauge:

100mm - 200mm Width = 4.0mm

300mm - 400mm Width = 4.3mm

500mm - 600mm Width = 4.6mm

The below drawings show in red the section cuts that are needed for the bends, tees and changing levels as explained in the Installation section on pages 291-292.

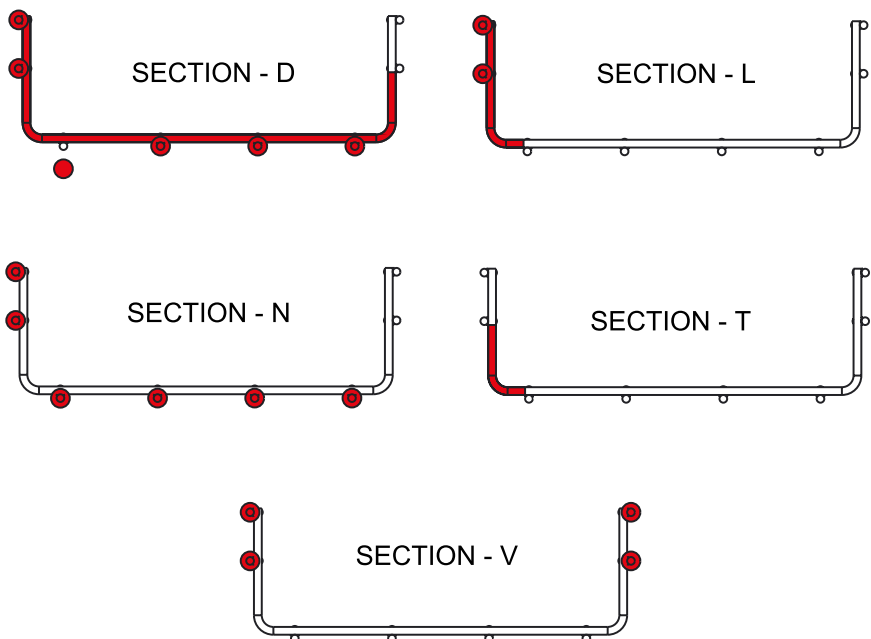

Horizontal bends long radius – right angle

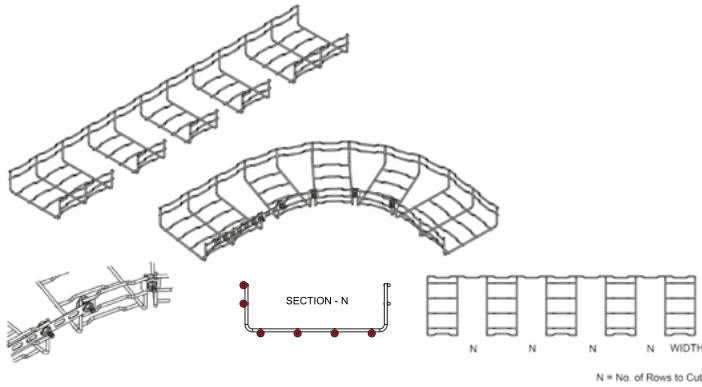

Horizontal tees

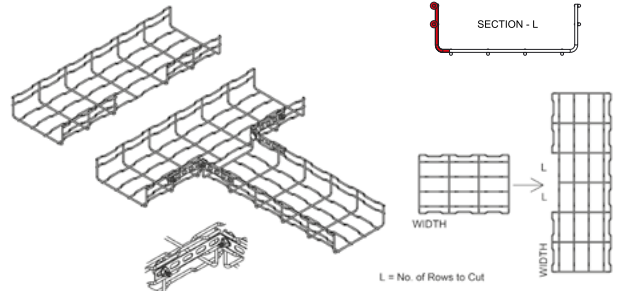

Tee with large radius

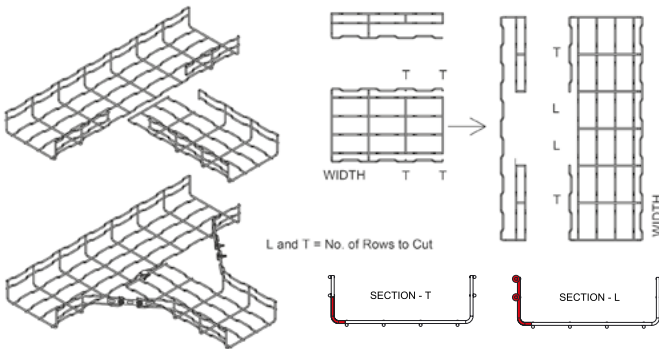

Vertical inside and outside bends

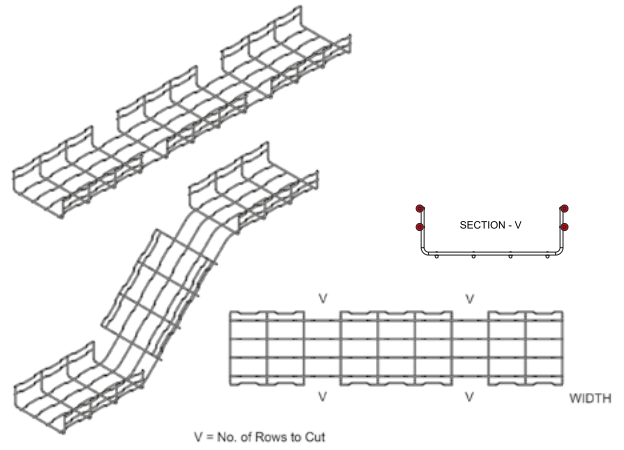

Reducers straight

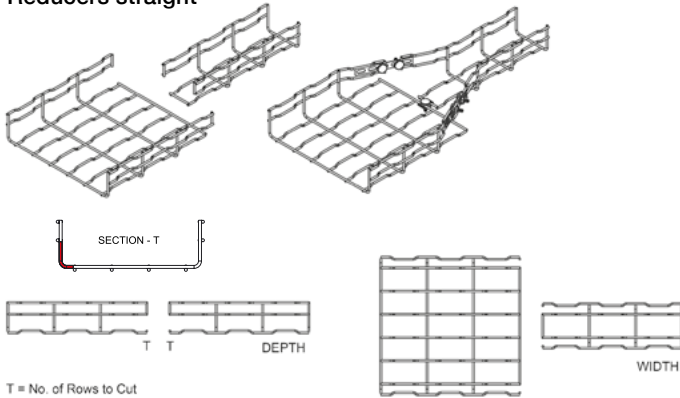

Reducers left or right

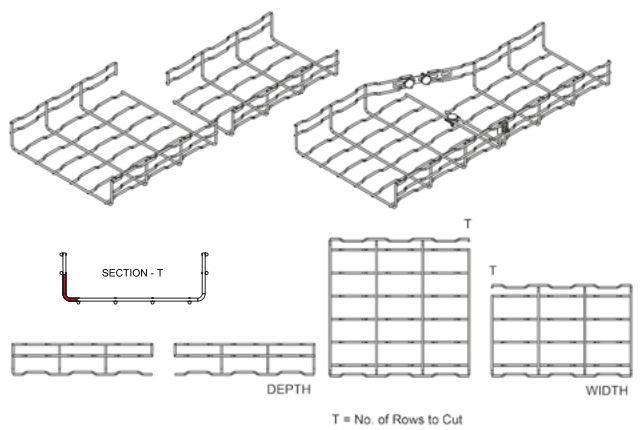

Vertical bends

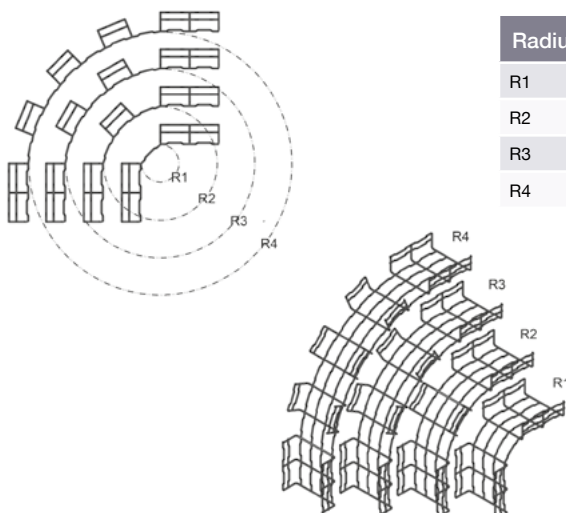

Radius	Radius diameter	Number of rows that will need to be cut
R1	64mm	1 row
R2	190mm	2 rows
R3	320mm	3 rows
R4	445mm	4 rows

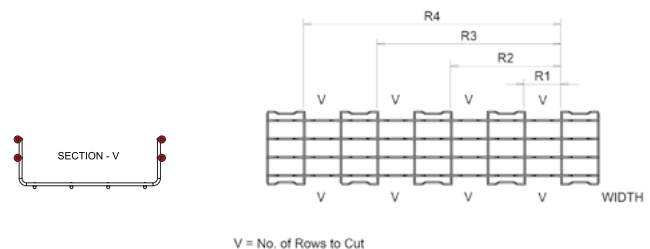

Marshall-Tufflex Ltd

55-65 Castleham Road
St Leonards on Sea
TN38 9NU
United Kingdom

T +44 (0)1424 856600
E sales@marshall-tufflex.com
www.marshall-tufflex.com

Technical Hotline:
+44 (0)1424 856688



Collect your order from our branches:

Manchester (M26 1GG)
Watford (WD18 0EZ)
Hastings (TN38 9NU)

Republic of Ireland & Northern Ireland distributor

Core Electrical Ltd
17b Goldenbridge Industrial Estate
Tyrconnell Road, Inchicore
Dublin 8

T +353 (0)1453 7033

In pursuance of our policy of continued product improvement Marshall-Tufflex reserve the right to change the design or specification of its products without notification.

**UK OWNED
UK MANUFACTURER**

