

MARSHALL-TUFFLEX

Aluminium XL Dado Trunking System



UK OWNED
UK MANUFACTURER



INSTALLATION INSTRUCTIONS

PLANNING INSTALLATION

Establish layout, paying attention to; direction of changes, Feed position & Component spacing.

CLEANING

The exterior should be cleaned using a damp cloth.

DISPOSAL INSTRUCTIONS

The product and packaging should be disposed of via standard civic amenity facilities.

Please note that the materials used are all 100% recyclable.

To ensure a safe installation, this product must be installed by a skilled or instructed person in accordance with current edition of UK IEE wiring regulations (BS 7671) and building regulations.

For product classification refer to DOC03752.

If you are in any doubt regarding the installation or application of the product, please contact: The Technical Team on +44 (0) 1424 856688.

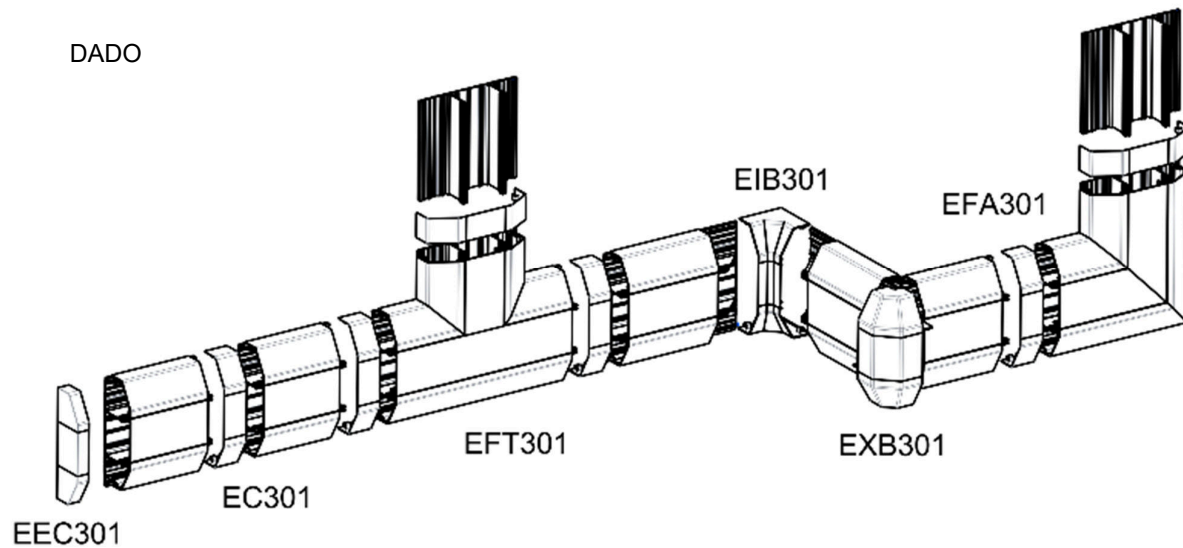

[1] When fitting trunking be mindful of:

When run against a vertical wall, sufficient clearance must be allowed for between wall and the profile fittings that clip over the covers (End Cap, Coupler, Internal and External Bends).

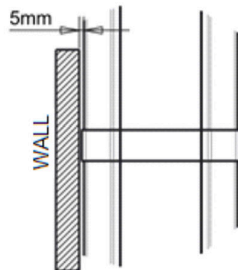

[2] Fitting of trunking

To fasten the base use No.8 round head screws & washers, Use of plastic caps over screw heads is recommended to protect cables.

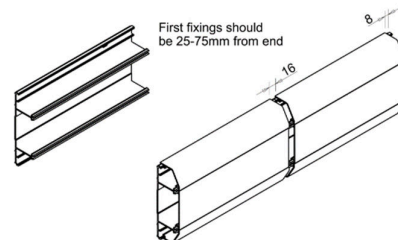

Base to base and Lid to Base bonding on all sections of trunking is recommended to maintain continuity – when fitting fabricated fittings bonding from trunking base to fabrication base is also recommended.

[3] Retention of Fittings

All fittings clip into the trunking base with exception of the End Caps. No additional fastening device is necessary. All are provided with a generous 10mm+ overlap at joints, to compensate for errors in cutting.

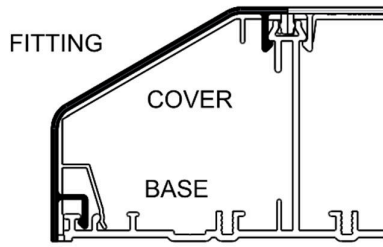

[4] Secured End Caps

End Caps butt up to the end of the base. No. 8 round head Fixing screws are recommended for the retention of the end cap.

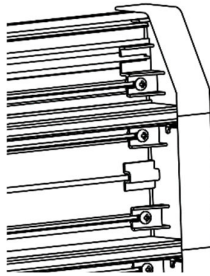

[5] Internal & External Bends

Base for Internal bend to be mitred 45° to ensure total enclosure of cables. for external bends base can be cut square to wall. Allow 3mm gap for variation in cuts.

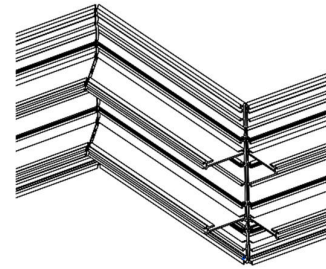

[6] Internal Bends

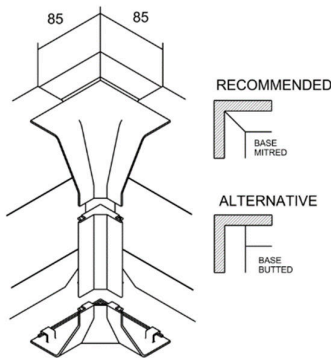

After fixing base to corner, fit covers with offset as shown then clip Internal bend in place.

[7] External Bends

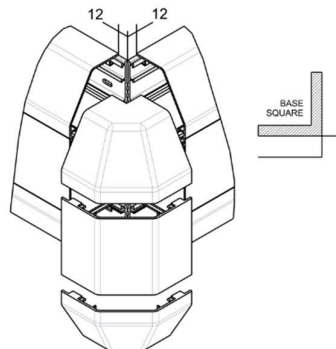

After fixing base to corner, fit covers with offset as shown then clip External bend in place.

[8] Offset Dimensions

The minimum set that can be accommodated in the same plane (from Internal to External bend).

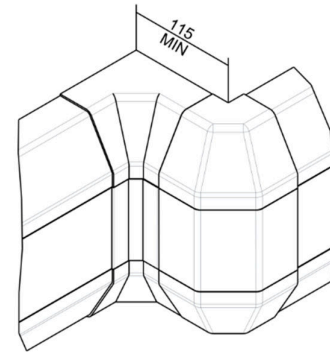

[9] Cover removal

The lids have been designed to remain in position irrespective of impact during normal conditions and minor undulations of fixing surface, all lids peel off once a tool has been used to pry the lid from the base, then simply peel lid away. To remove the side covers first remove centre lid then insert tool into inner leg at base and lever out, this will be quite ridged and may take some force.

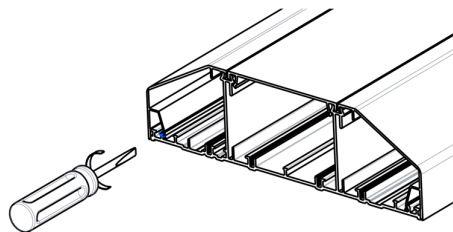

[10] Method of Continuation Through a Partition Wall

Continue the main lateral run of base through the partition with short lengths of cover fitted where the trunking passes through the partition. The partition wall trunking is then butted up to the main run and the joint covered by an internal bend

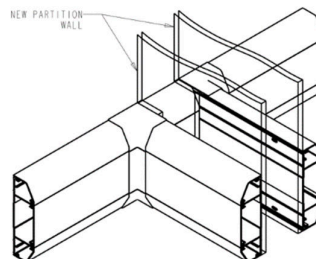

[11] Short Length

To fit a single length of trunking (under 3 metres) between two inside walls and with no accessory box fitted; it is advisable to install a coupler in the centre of the run to facilitate the removal of the cover

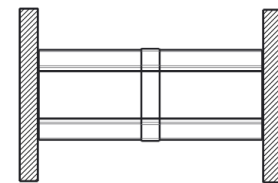

[12] Flat Angle and Flat Tee

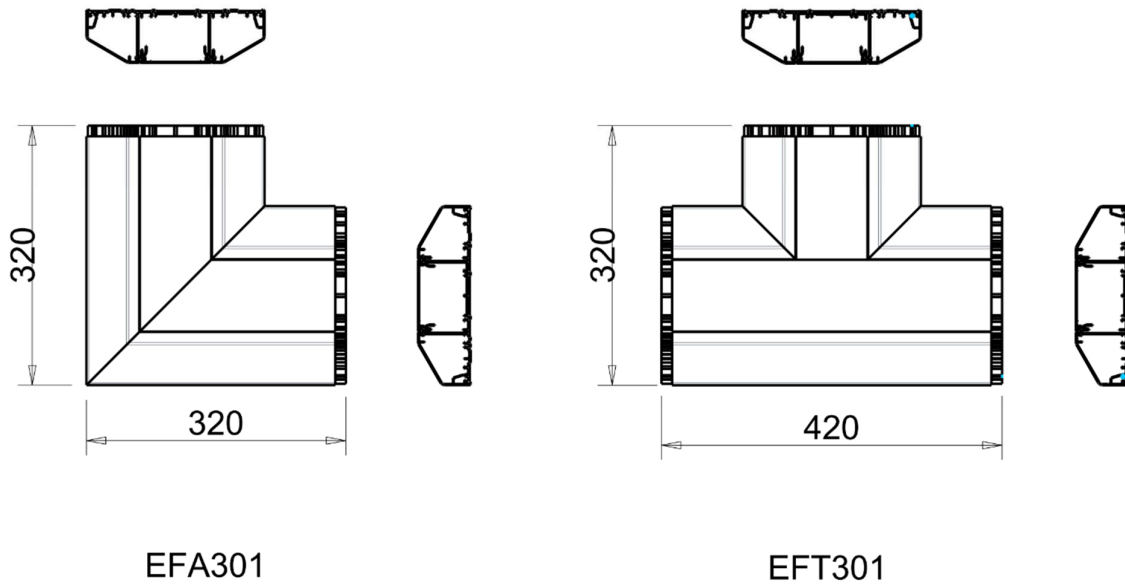

Flat Angle and Flat Tee to be assembled as shown in illustration, Fabrications have covers recessed 15mm to allow fitment of coupler with 10mm overlap. 2 couplers needed for Flat Angle and 3 couplers needed for Flat Tee.